

DESIGN NOTES

LTC1626: Step-Down Converter Operates from Single Li-Ion Cell – Design Note 196

Tim Skovmand

Introduction

The LTC1626 is a low voltage, high efficiency, monolithic step-down DC/DC converter featuring an input supply voltage range of 2.5V to 6V, which makes it ideal for single-cell Li-Ion applications. A built-in low $R_{DS(ON)}$ switch provides high efficiency and allows up to 0.6A of output current. The LTC1626 incorporates automatic power saving Burst Mode™ operation to reduce gate-charge losses when the load current drops. With no load, the converter draws only 160 μ A and in shutdown it draws a mere 1 μ A, making it ideal for current-sensitive applications.

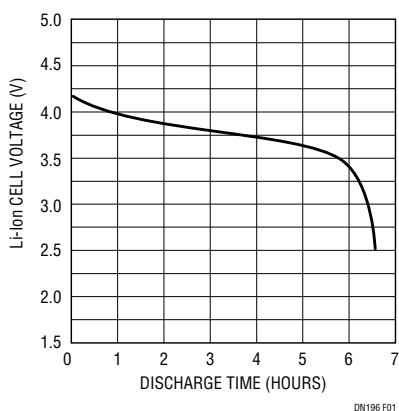

Figure 1. Typical Single-cell Li-Ion Discharge Curve

Single-Cell Li-Ion Operation

As shown in Figure 1, a fully charged single-cell Li-Ion battery begins the discharge cycle between 4.1V and 4.2V. During most of the discharge period, the cell produces between 3.5V and 4.0V. Toward the end of discharge, the cell voltage drops fairly quickly below 3V. The discharge is typically terminated somewhere around 2.5V (depending upon the manufacturer's specifications).

The LTC®1626 is specifically designed to accommodate a single-cell Li-Ion discharge curve. For example, using the circuit shown in Figure 2, it is possible to produce a stable 2.5V/0.25A regulated output voltage with as little as a 2.7V from the battery, thus obtaining the maximum run time possible.

100% Duty Cycle in Dropout Mode

As the Li-Ion cell discharges, the LTC1626 smoothly shifts from a high efficiency switch mode DC/DC regulator to a low dropout linear regulator (that is, 100% duty cycle). In this mode, the voltage drop between the battery input and the regulator output is limited only by the load current and the series resistance of the PMOS switch, the current sense resistor and the inductor. When the battery voltage rises again, the LTC1626 smoothly shifts back to a high efficiency DC/DC converter.

Ⓜ, LTC and LT are registered trademarks of Linear Technology Corporation. Burst Mode is a trademark of Linear Technology Corporation.

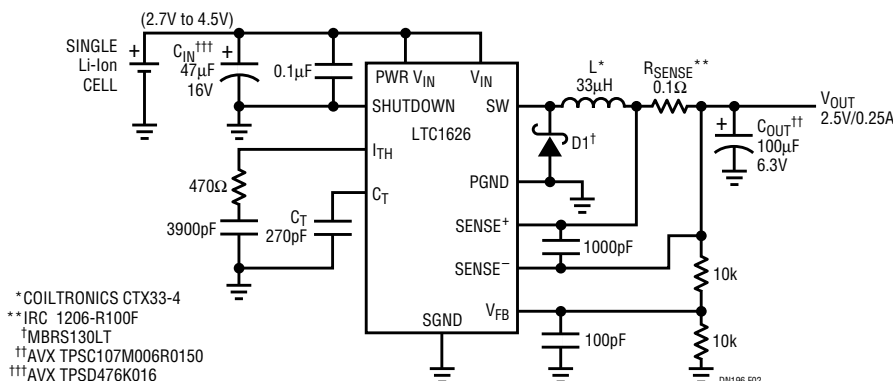

Figure 2. Single-Cell Li-Ion Battery to 2.5V Converter

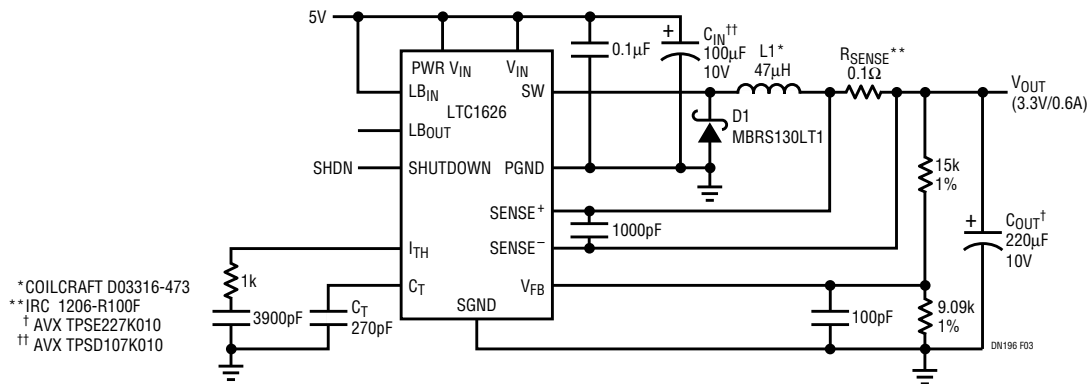

Figure 3. High Efficiency 5V to 3.3V Step-Down Converter

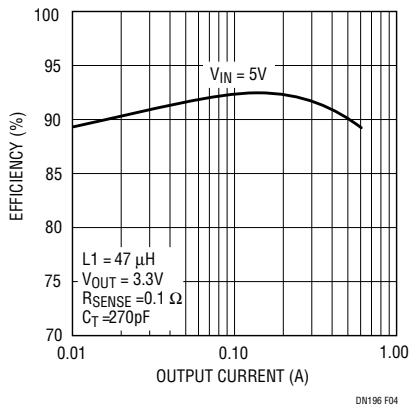

Figure 4. Efficiency vs Load Current

High Efficiency 5V to 3.3V Conversion

The circuit of Figure 3 shows the LTC1626 being used for board-level conversion of 5V to 3.3V at up to 0.6A. Although a linear regulator could also perform this function, it would result in an additional 1W of power loss. The high efficiency of the LTC1626 (Figure 4) reduces this loss to only 230mW.

Current Mode Architecture

The LTC1626 is a current mode DC/DC converter with Burst Mode operation. This results in a power supply that has very high efficiency over a wide load-current range, fast transient response and very low dropout characteristics. Further, the inductor current is predictable and well controlled under all operating conditions, making the selection of the inductor much easier.

Current mode control also gives the LTC1626 excellent start-up and short-circuit recovery characteristics. For example, when the output is shorted to ground, the off-time is extended to prevent inductor current runaway. When the short is removed, the output capacitor begins to charge and the off-time gradually decreases. The output returns smoothly to regulation without overshooting.

Low Voltage Low $R_{DS(ON)}$ Switch

The integrated PMOS switch in the LTC1626 is designed to provide extremely low resistance at low supply voltages. Figure 5 is a graph of switch resistance versus supply voltage.

Note that the $R_{DS(ON)}$ is typically 0.32Ω at 4.5V and only rises to approximately 0.40Ω at 3.0V. This low switch resistance ensures high efficiency switching as well as low dropout DC characteristics at low supply voltages.

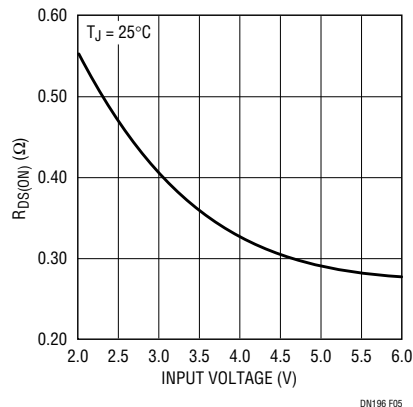

Figure 5. PMOS Switch Resistance vs Input Supply Voltage

Conclusion

The LTC1626 is specifically designed to operate from a single-cell Li-Ion battery pack. With its low dropout, high efficiency and micropower operating modes, it is ideal for cellular phones and handheld industrial and medical instruments.

For literature on our DC/DC Converters, call **1-800-4-LINEAR**. For applications help, call (408) 432-1900, Ext. 2377